

RC-25A-P RevoCast™ Granule Spreading System

User Manual

Version 1.0 **EN**

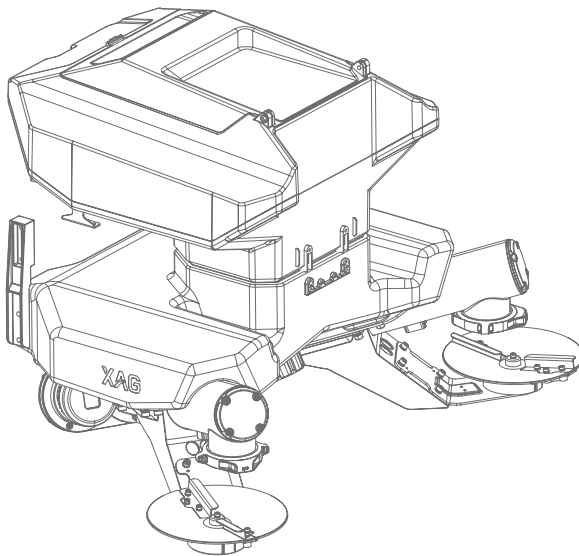

XAG

To Users

Dear user, thank you for choosing XAG products.

For safety purposes and better user experience, it is highly recommended that you read this manual carefully and strictly follow the instructions hereof.



Click to View

The Contents hereunder will give you a broad outline of this manual. Click on the title to jump to the relative page.

Contact Us

If you have any questions about this document, please contact our Technical Support team via email: info@xa.com

Contents

List of Items	1
Structure	2
Before Installation	3
Drain the Tube	3
Remove RealTerra	5
Remove Spraying Hub Housing	5
Remove Water Pump Set	6
Install Spreading System	7
Install Granule Payload Detection Panel	7
Install Granule Container Kit	8
Install Granule Payload Detection Module	9
Install Upper Granule Container	9
Wiring Guidelines	12
Install Spraying Hub Cover	14
Use Spreading System	14
Spreading Calibration	14
Manual Spread Testing	20
Spreading Settings	21
Appendix	25
Wiring Quick Guide	25
Specifications	26
Precautions	27
Disclaimer	28

List of Items

Please check that the following items are all present when unpacking the box. Should there be any items missed, please contact your dealer.

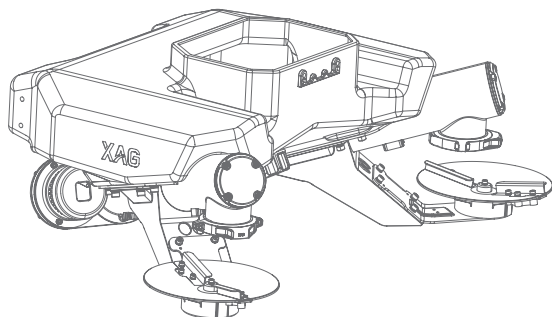

Granule Container Kit
×1

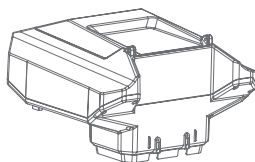

Upper Granule Container
×1

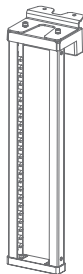

Granule Payload Detection Module
×1



Accessory Kit
×1

Structure

The main components of the granule systems are as follows.

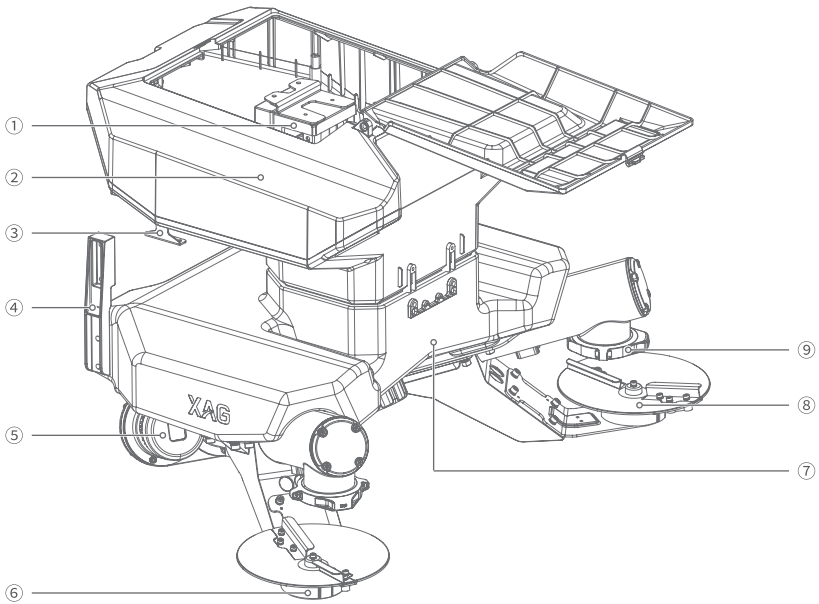

- ① Granule Payload Detection Module
- ② Upper Granule Container
- ③ Upper Granule Container Bracket
- ④ Lower Granule Container Bracket
- ⑤ Feeding Motor

- ⑥ Spreading Disc Motor
- ⑦ Lower Granule Container
- ⑧ Spreading Disc
- ⑨ Feeder Detection Module

Before Installation

RC-25A-P Granule Spreading System works with XAG 3WWDZ-20B Agricultural UAV, i.e., P40 Agricultural UAV. The spraying system should be removed prior to installation.

Drain the Tube

Residual pesticide should be thoroughly rinsed and drained from the spraying system prior to dismantling the spreading system.



- Open XAG One App. Click "Device Details" - "Device Status" to go to the device status page.



- Infuse the liquid tank with soapy water. Start spraying manually in the "Spray" page to rinse the residual pesticide in the spraying system.
- Pour out the soapy water and infuse clean water. Start spraying manually in the "Spray" page to rinse the residual soapy water.



- Remove the liquid tank and click "Drain the Tube".



- Select "Drain the liquid from the tube" to turn on the spraying pump and drain off the residual liquid from the tube.

Remove RealTerra

Remove RealTerra from the slot.

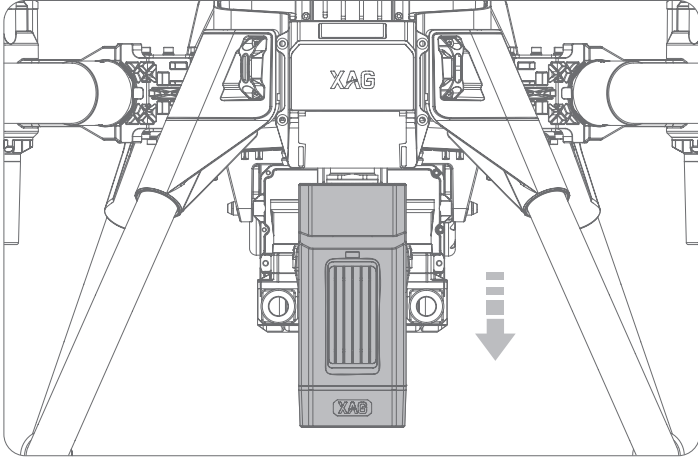

Remove Spraying Hub Housing

Remove the spraying hub housing by unscrewing its 6 screws (2 on the top and 2 on both left side and right side).

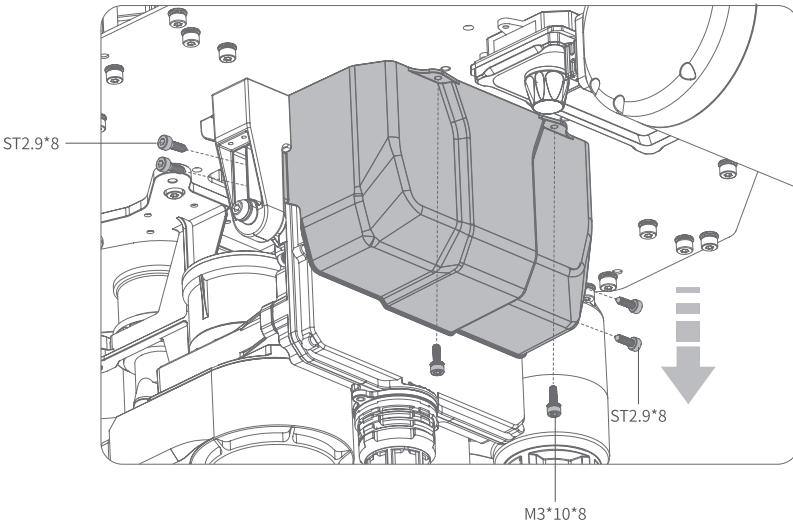

Remove Water Pump Set

Pull the liquid tank signal cable, left/right nozzle signal cable and left/right pump signal cable out of the spraying hub.

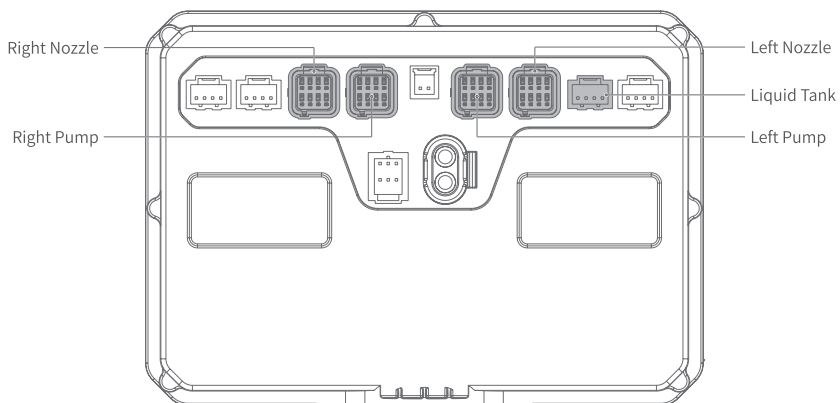

Pull out the infusion tubes of arm No.3 and No.4 and push them into the beam.

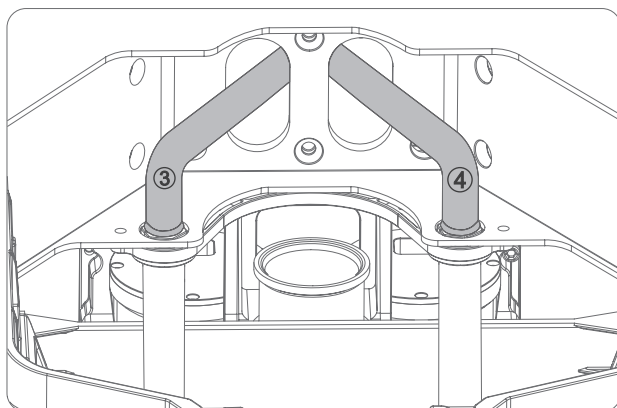

Remove the water pump set by unscrewing its 8 screws (2 on the left side and right side of the top and 4 peristaltic pump setscrews on the bottom).

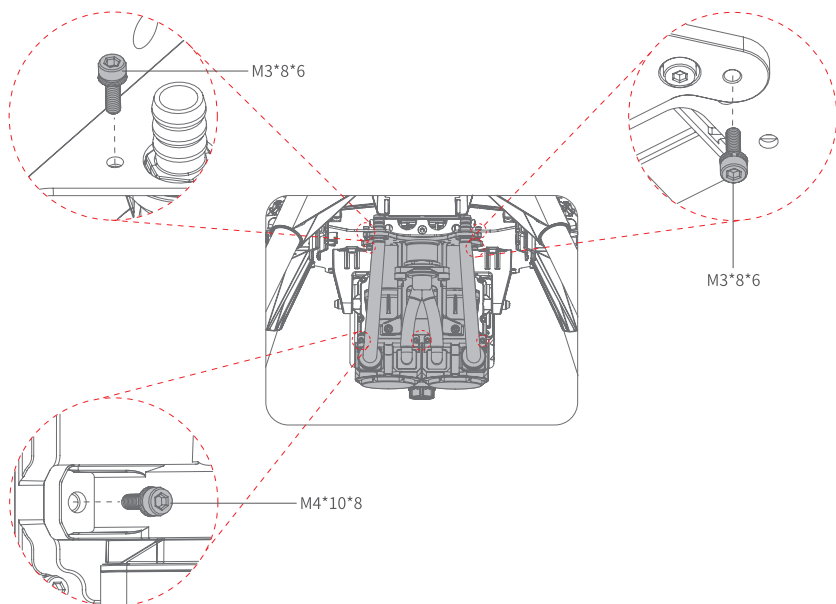

Install Spreading System

Install Granule Payload Detection Panel

Screw the granule payload detection panel to the pump driver board with 2 screws.

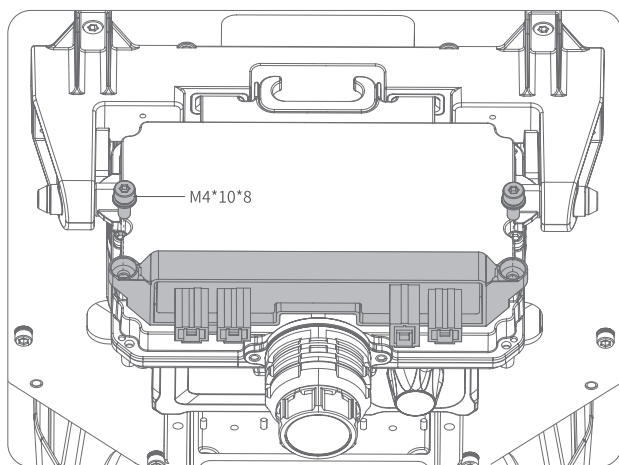

Install Granule Container Kit

Remove the left/right U hook by unscrewing its 2 screws.

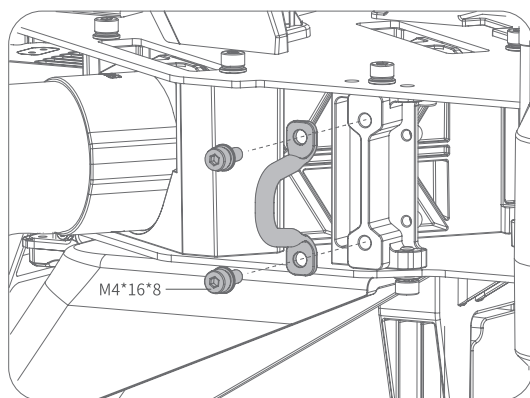

Place the granule container kit under the drone and screw the left/right U hook and rear frame beam as shown below.

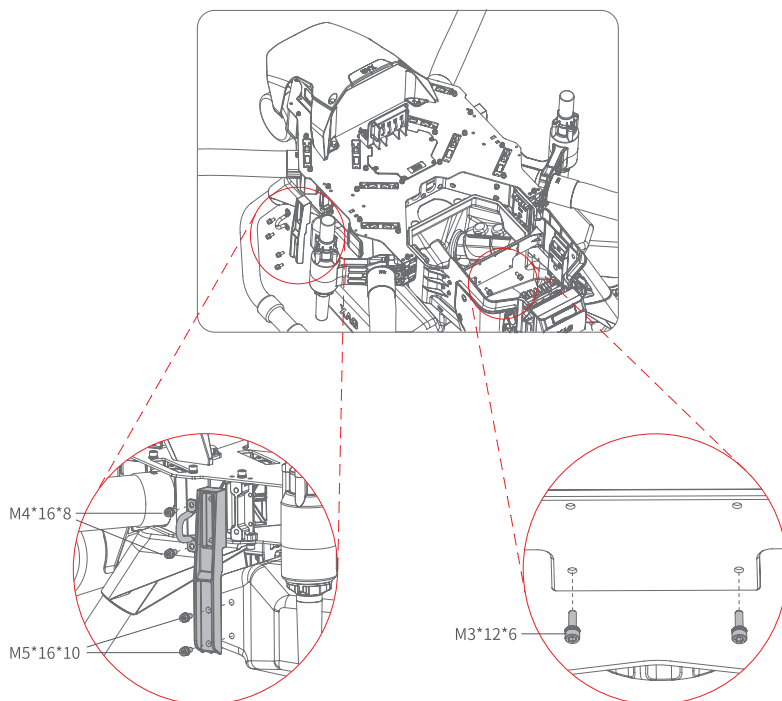

Note ⚠ Lift up the drone and put it flat against the wall may facilitate the RevoCast installation.

Install Granule Payload Detection Module

Put the granule payload detection module into the upper granule container, pull its infrared sensor cable (HD) through the hole below and secure the module with 2 screws.

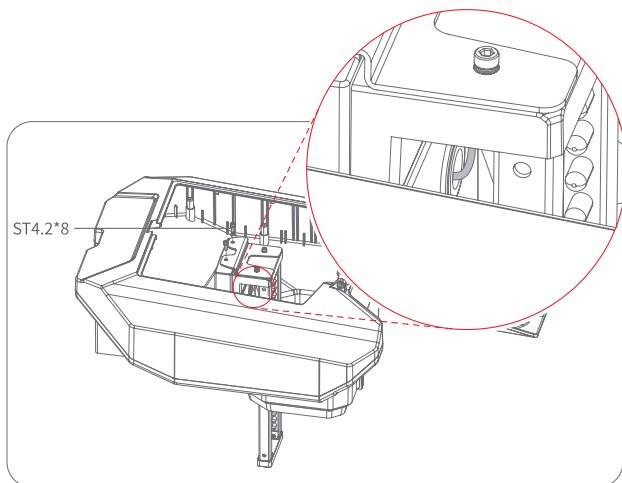

Install Upper Granule Container

Screw the upper granule container bracket on the holes between arm No.3 and No.4 with 2 setscrews.

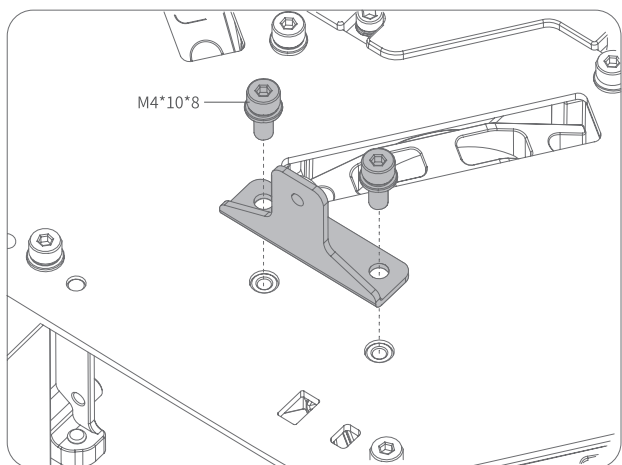

Unscrew the 6 screws on the central hatch cover. Lift it up and put the infrared sensor cable (HD) into the hole in the front of the cover. Then install the central hatch cover back to the original place securely.

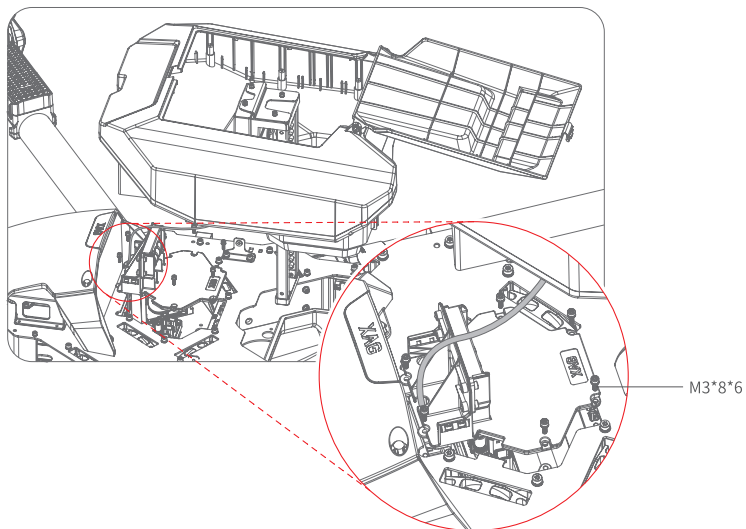

Pull the infrared sensor cable (HD) from the hole on the top of the spraying hub to its back.

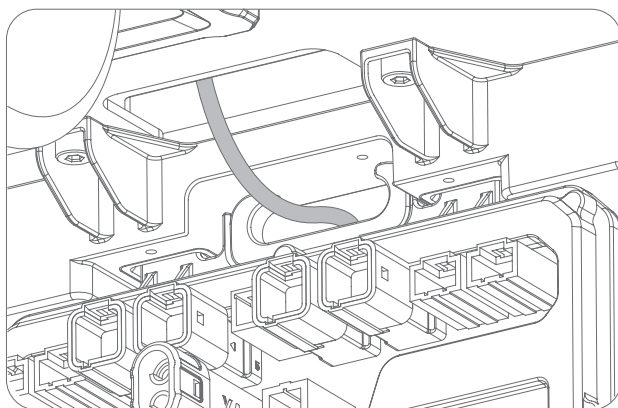

Place the upper granule container into the central hatch and secure it with 2 screws (1 on the left and 1 on the right).

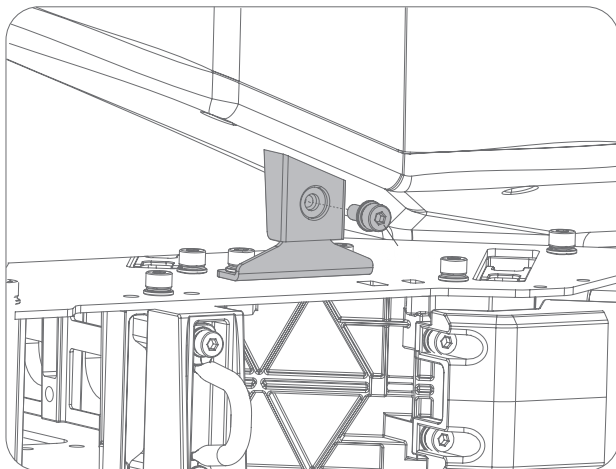

Screw the upper granule container to the rear frame beam with 2 screws.

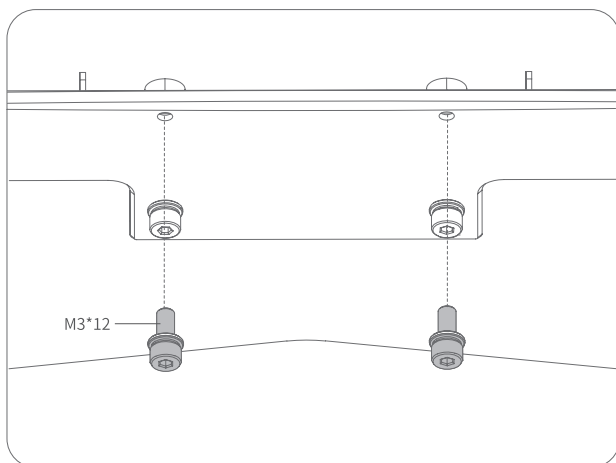

Screw the lower granule container to the granule payload detection module with 2 screws.

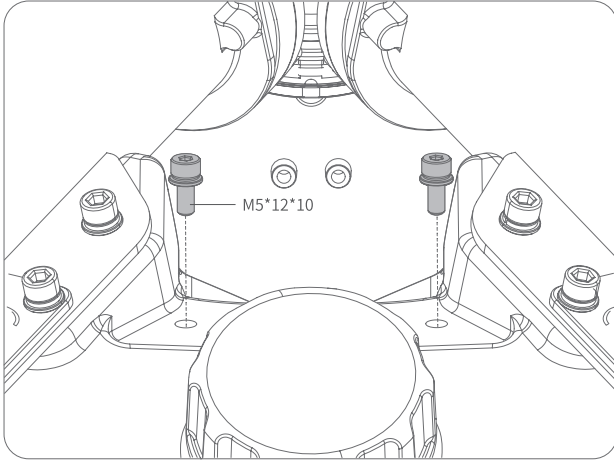

Wiring Guidelines

Wire Infrared Sensor Cable

Connect the infrared sensor cable (HD) to the granule payload detection panel.

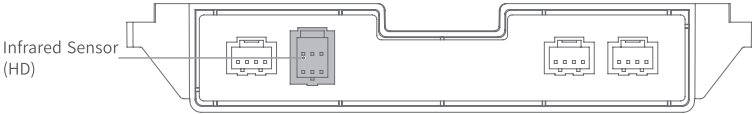

Connect Outlet Detection Signal Cable

Connect the left/right outlet detection signal cable (OUT-R/L) to the granule payload detection panel.



Connect Granule Payload Detection Signal Cable

Pull the granule payload detection signal cable (CP) from the hole on the top of the spraying hub. Connect it to the granule payload detection interface on the spraying hub.

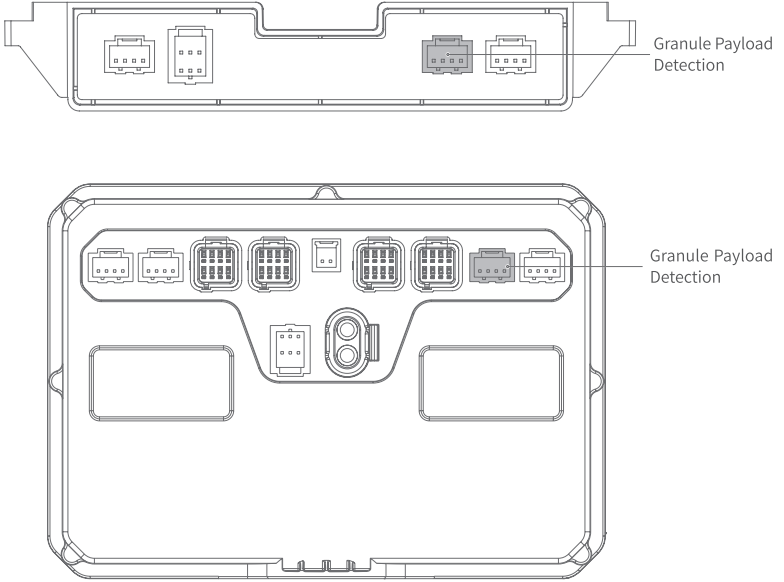

Connect Feeding Motor Power Cable and Spraying Disc Motor Power Cable

Pull the left/right feeding motor power cable (FALL-R/L) of the spreading system and the left/right spraying disc motor power cable (THROW-R/L) from the hole on the top of the spraying hub. Connect them to the corresponding interface on the spraying hub.

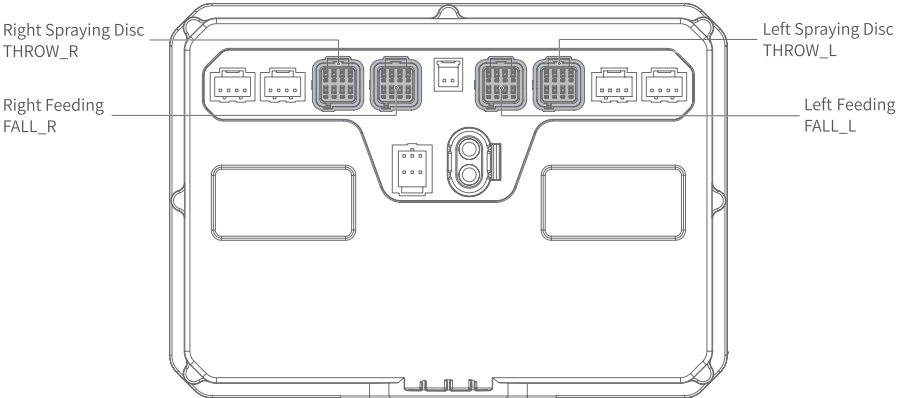

Install Spraying Hub Cover

Install the spraying hub cover back to its original place.

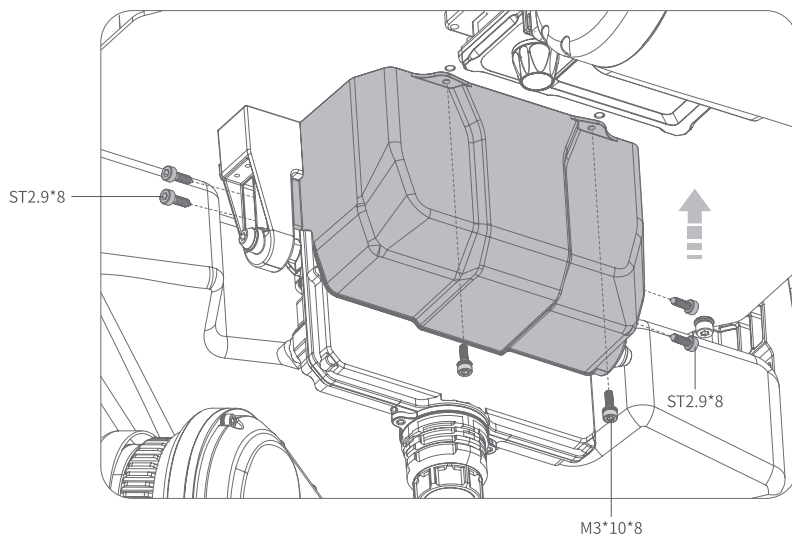

Use Spreading System

Spreading Calibration

It is required to calibrate the spreading system before your first use or after switching to other granules. Remove the left and right spreading discs by unscrewing the setscrews before calibration.

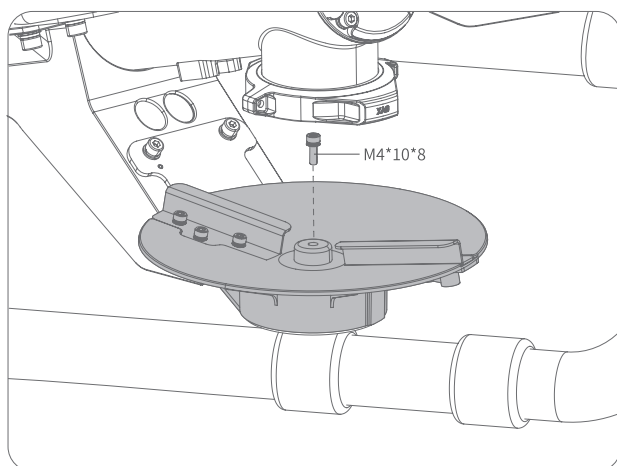



- Open the XAG One App and swipe left/right to select the device for operation. Click "Device Details" to go to the device detail page.



- Select the "Spread" page and click "Spread Granule".



- Click ⊕ on the top right corner. After entering the name of the granule that needs calibration, click "Confirm". Select that granule and back to the "Spread" page.



- Click "Spreading Calibration".



- Place the drone at around 50cm above the ground. Get a handheld scale and tare it after hanging a bag/receptacle on its hook. Then fix the bag/receptacle on the S1 discharge outlet.
- Fill the granule container with granules to be calibrated of around 2/3 of the granule container capacity.
- Upon completion of the above steps, click "S1 Start Discharging".

⚠ Please ensure that the drone has been placed at around 50cm above the ground and there is a bag/receptacle on the discharge outlet before calibration.

⚠ During calibration, attention should be paid to prevent the granules from spilling out of the bag/receptacle and clogging up the discharge outlet, which may lead to discharge failure.

⚠ For your safety, never touch the discharge tube, screw feeder or other running components during calibration.



- After S1 stops discharging, weigh the bag/receptacle and the granules with the handheld scale. Enter the net weight of the granule in gram in the App.
- Click "Submit" to complete the S1 calibration.

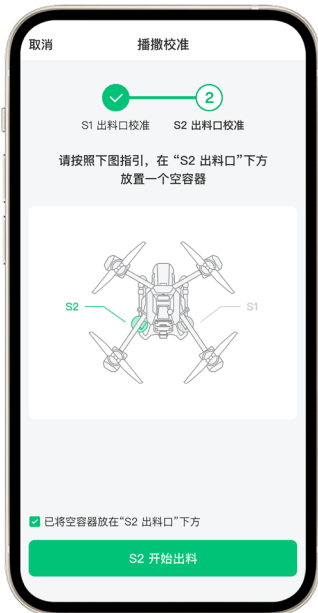

- Tare the handheld scale after hanging a new bag/receptacle on its hook. Then fix the bag/receptacle on the S2 discharge outlet.
- Fill the granule container with granules to be calibrated of around 2/3 of the granule container capacity.
- Upon completion of the above steps, click "S2 Start Discharging".

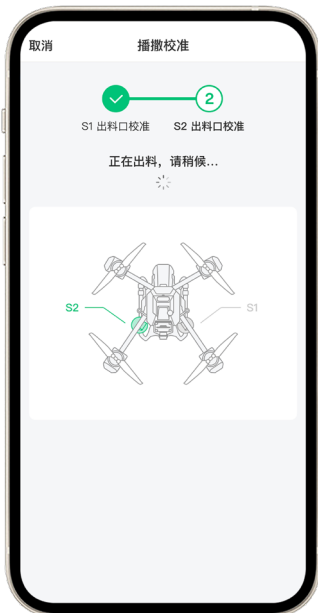

- After S2 stops discharging, weigh the bag/receptacle and the granules with the handheld scale. Enter the net weight of the granule in gram in the App.
- Click "Submit" to complete the S2 calibration.



- Spreading calibration is completed.

Install the left/right spreading disc back to its original place.

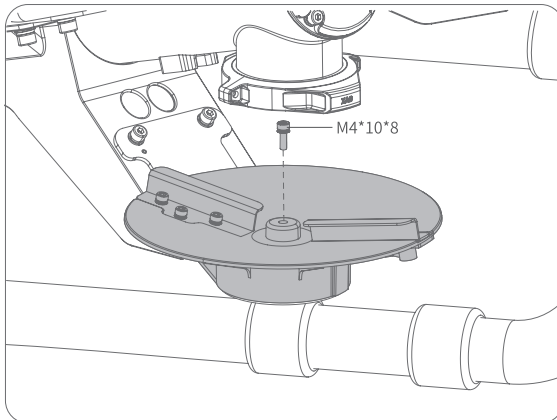

💡 Rotating Direction and Installation of the Left/Right Spreading Disc

- Open XAG One App and go to the "Spread" page. Click "Manual Spreading Test" to start manual spreading test for S1 and S2 spreading discs. They are properly installed when you see, viewing from the rear, that the left spreading disc is rotating clockwise and flinging the granule outward from the concave side of the vanes while it is the same for the right spreading disc but rotating counterclockwise.

Manual Spread Testing

Manual spread testing is required before any spreading operation to ensure that the spreading system is feeding properly.



- Enter the "Spreading" page and tap on "Manual Spread Testing".

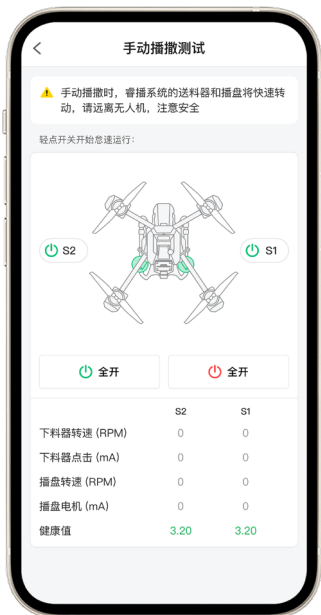

- Click on spreader S1/S2 to conduct manual spread testing.
- ⚠️ The feeder and spreading disc will rotate rapidly during manual spreading. Please stay away from the drone to avoid accidents.

Spreading Settings

Before spreading, user may set parameters required for operation via "Spreading Settings".



- Open the XAG One App, swipe left/right to select the device for operation. Tap on "Start Operation" to get to the operation page.

⚠ The drone will be unable to spread when equipped with the RealTerra.



- Press and hold the drone icon in the menu bar at the bottom, and drag it to the field for operation.



- Tap on "Spreading Settings".

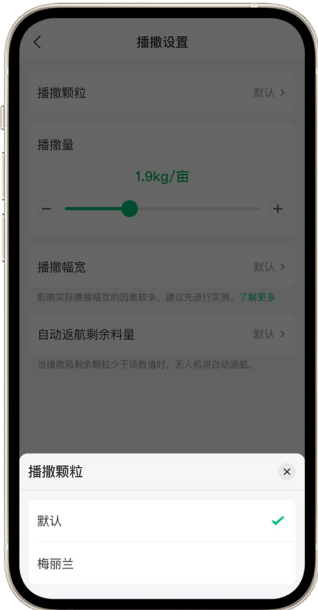

- Tap on "Granule" and select what to spread.



- Move the slider to adjust the spread amount.



- Tap on "Spread Width" to select the width.

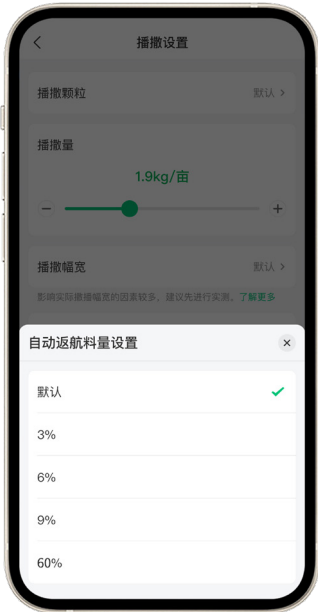

- Tap on "Auto Return Amount", and select the remaining granule amount for the drone to return automatically.



- After completing route settings, you may turn on the drone and start spreading.

Appendix

Wiring Quick Guide

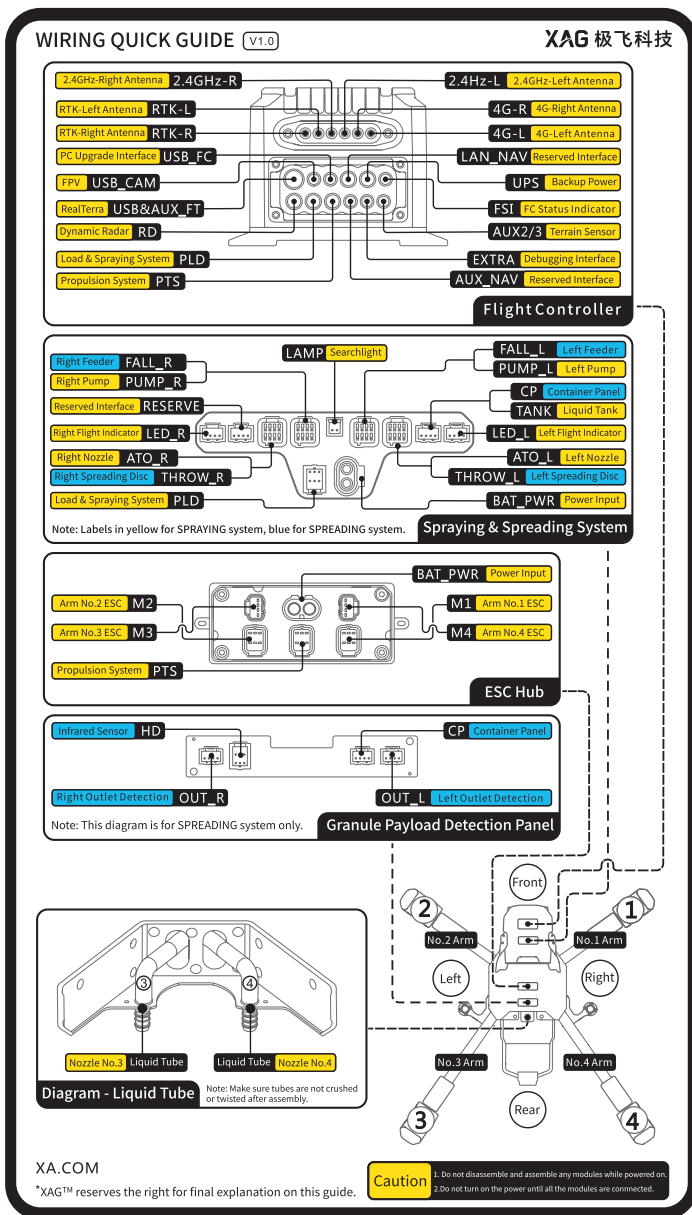

Specifications

Model	RC-25A-P
Compatible with	XAG 3WWDZ-20B Agricultural UAVs
Net Weight	5.5kg
Capacity of Granule Container	25L
Rated Payload of Granule Container	18.5kg
Dimensions	675*480*438mm
Protection Rating	IP65
Operating Temperature	0° C to 40° C
Storage Temperature	0° C to 40° C
Spread Width	4-10m (Subject to operating altitude, seed types, dosage and rotational speed of spreading discs)
Applicable Granule Size	1-10mm (Dry and solid granule)
Spread Amount Precision	±10% (Subject to the shapes and moisture of seeds)

Contents concerning XAG App in this document will be refined and updated on a regular basis in electronic form. Please scan the QR code to read or download the latest version of "RC-25A-P RevoCast™ Granule Spreading System User Manual".



Precautions

- RC-25A-P RevoCast Granule Spreading System is designed only for XAG 3WWDZ-20B Agricultural UAVs. Do NOT use on other products or for purposes other than plant protection.
- This Granule Spreading System works with dry and solid granules with a diameter of 1 to 10mm. The granules should be kept from sticking to the hands.
- Do NOT use unspecified granules as they may affect operations, or even cause damage to the spreading system. Please follow the instructions of the granules exactly when you use them.
- The Granule Spreading System is recommended to be used in sunny, cloudy or overcast days with a wind force below 3, and an environment without interference including powerful magnetic fields.
- The Granule Spreading System is not allowed to be used in bad weather with rain, snow, frost, fog, thunder, hail, dust and strong winds as well as an environment with interference including powerful magnetic fields.
- Before operation, please ensure that the spraying discs of all nozzles have been removed.
- Before each operation, check if the feeding motor, spreading disc motor and granule payload detection module are working properly. Calibrate with the granules to be spread.
- Non-XAG granule container is prohibited. Damages caused by unauthorized modification or increase of granule container capacity will not be covered by warranty, and user shall take sole responsibility for such damages.
- During operation, pay attention to the remaining granules in the container and return to replenish when they are running out.
- Be careful during operation. Do NOT touch the operating feeding motor or spreading disc motor as this might cause injury.
- Stay away from the operating drone to avoid bodily harm.
- After operation, empty the granule container. Turn off the power and rinse the container, feeding tube, spreading discs as well as the granule payload detection module with clean water to remove residual granules. Place the spreading system in the shade and let it dry.
- NEVER wash or rinse the spreading system when the power is on.
- NEVER leave granules in the container, or they might cake when getting damp, thus affecting the starting up of motors or feeding precision.
- NEVER leave granules in the spreading discs for a long time to keep their vanes from becoming damp which may affect spread width.

Disclaimer

01. Please read this User Manual carefully before using the product, as it has much to do with both operational safety and your legitimate rights and interests. You shall be deemed to acknowledge, understand, agree to and accept all terms and conditions as well as content stated herein upon activation of this product.
02. Not being a toy, plus for certain safety risks, this product is not suitable for those who are under 18 years old, or those without a UAS operator certificate accredited by XAG or existing laws, regulations and policies. Please keep the children away from this product and be particularly cautious with children present.
03. This product is a spreading accessory of XAG 3WWDZ-20B Agricultural UAVs solely designed for agricultural use. With activation in accordance with the User Manual, properly functioned battery and data indicated as normal, it will provide you with safe and satisfactory plant protection service.
04. You commit to use this product only for a legitimate purpose and acknowledge the content stated herein as well as possible formulation and amendment of policies and norms by XAG. You understand, acknowledge and accept that flight records and data during operation will be automatically uploaded and saved to XAG's server as well as licitly collected and stored by XAG. XAG assumes no responsibility for the failure to store and analyze the flight records and data caused by the unsuccessful upload due to any reason attributable to you.
05. To the maximum extent permitted by law, under no circumstances shall XAG offer an implicit or explicit guarantee for this product, including but not limited to implicit guarantees pertaining to vendibility, fitness for a particular use, or non-infringement.
06. To the maximum extent permitted by law, XAG shall not be liable for all losses caused by your improper operation. Also, XAG shall not be liable for any indirect, consequential, punitive, accidental, special or exemplary damages, including any loss incurred as a result of your purchase, use, or inability to use the product (even if you have been advised of the possibility of such loss).
07. To the maximum extent permitted by law, under any circumstances, the liability or compensation amount from XAG to you for all damages, losses, and litigation arising therefrom will not exceed the amount that you paid to XAG or XAG accredited distributor for purchasing the product.
08. On any account, the purchaser or user shall comply with laws and regulations of the country and region where the product is used. XAG assumes no liability arising from the violation of relevant laws and regulations by the purchaser or user.
09. As exclusion clauses may be prohibited by laws in some countries, your rights in different countries may vary. This does not imply that the content contained in this Disclaimer is necessarily invalid.
10. To the extent permitted by law, XAG reserves the right for final explanation and revision of the terms and conditions stated herein. XAG also has the right to update, modify or terminate these terms and conditions via its official website, the Instruction Manual/User Manual, online APP, etc., without prior notice.

Warning

Users are required to read the full User Manual and obtain UAS operator certificate accredited by XAG (or recognized by existing laws, regulations, and policies of the country or region where the product is used). Otherwise, it may cause serious injury to the user or others, or cause damage to the product and property loss. Safety awareness is of paramount importance during operation. This product is not suitable for children or those who are under 18 years old. Do NOT use the parts that are not provided or suggested by XAG. Please install and use the product by strictly following XAG's User Manual.



info@xa.com



@XAGofficial



@XAG_official



YouTube @XAG Official



This document is subject to update without prior notice.

©Guangzhou Xaircraft Technology CO., LTD. All Rights Reserved.

All information of this User Manual (including but not limited to any text description, illustrations, photos, methods and processes, etc.) belongs to Guangzhou Xaircraft Technology CO., LTD. and is protected by copyright law. Without written authorization, no individual or institution is allowed to reproduce, extract, translate, distribute, or otherwise reproduce or quote any content hereof.