

# XAG RevoCast P3

## User Manual

Version 1.0 EN

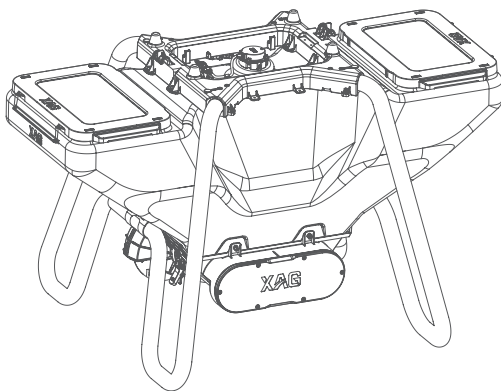

## **To User**

Dear user, thank you for choosing XAG's products.

For safety purposes and better user experience, it is highly recommended that you read this manual carefully and strictly follow the instructions hereof.

## **Contact Us**

Manufacturer: Guangzhou Xaircraft Technology CO., LTD.

Add: XSpace, No.115, Gaopu Road, Guangzhou, Guangdong Province, China

Technical Support Team: support@xa.com

# Contents

<b>Safety Guidelines</b>	1
<b>Introduction</b>	2
<b>List of Items</b>	2
<b>Main Components</b>	2
<b>Installation</b>	3
Drain the Liquid	3
Remove RevoSpray	3
Install RevoCast	6
<b>How to Use</b>	6
Firmware Update	6
Spreading Calibration	7
Spreading Settings	8
<b>Maintenance</b>	8
Rinse RevoCast	8
Replace Screw Feeder	10
Granule Examples for Different Sized Screw Feeders	11
<b>Specifications</b>	11
<b>Disclaimer</b>	13

# Safety Guidelines

- XAG RevoCast P3 (Model: M4RC-80A-PH) is only compatible with XAG P100 2023 Agricultural Drone and XAG P100 Pro 2023 Agricultural Drone. Do NOT use it on other products or for non-agricultural purposes.
- RevoCast only works with dry granules - nonsticky ones will be good - with a diameter of 1 to 6 mm.
- Do NOT use granules beyond the size range above as they may lead to less effective operations, or even cause damage to the RevoCast. Please follow the instructions of the granules exactly when you use them.
- It is advisable to use the product on sunny, cloudy or overcast days with winds of force 3 or below in an area free of strong electromagnetic interference.
- NEVER use the product in adverse weather conditions including rain, snow, frost, fog, thunder, hail, dust storm and gale or in an area with strong electromagnetic interference.
- Please install and use the product in strict accordance with this User Manual.
- Before operation, please ensure the spraying bars have been removed to avoid damage caused by the throwing granules.
- Before each operation, check if the feeding motor, spreading disc motor and radar level sensor are working properly. Calibrate with the granules to be spread.
- It is NOT allowed to use a non-XAG granule container, covert the container on your own or increase its capacity in that it may result in malfunctions, inefficient operations, or damage to the product, which are not covered by the warranty. User shall solely assume the liabilities for any loss arising therefrom, both financially and legally.
- During operation, pay attention to the remaining granules and return for replenishment when they are running out.
- Be careful during operation. Keep clear of the running feeding motor or spreading disc motor to avoid getting hurt.
- Stay clear of the working aircraft and RevoCast to avoid getting hurt.
- Please empty the granule container after operation. Turn off the power and rinse the container, feeding tube, spreading discs and radar level sensor with clean water to remove residual granules. Then air-dry the RevoCast in a cool place away from direct sunlight.
- NEVER wash the RevoCast when the power is on.
- NEVER store granules in the container, or they will get damp and clump, thus affecting the power-up of the motor or the feeding precision.
- NEVER leave granules in the spreading discs for a long time to prevent granules from sticking to the vanes, which may affect spread width.
- Please fully clean and check the product to make sure there is no blockage or other malfunctions when it is not in use. Store it in a dry, cool, and safe place.
- Accessories provided by non-XAG manufacturers are NOT allowed for use or repair as they may seriously affect the safety and service life of XAG's products. The warranty does NOT cover any damage to the product caused by using such accessories.

# Introduction

XAG RevoCast P3 ("RevoCast" for short), working with XAG P100 2023 Agricultural Drone and XAG P100 Pro 2023 Agricultural Drone, can be applied in various scenarios, from spreading seeds and fertilizers to providing feed for fish and shrimp in aquaculture, thus offering intelligent, precision, efficient, and flexible production solutions.

## List of Items

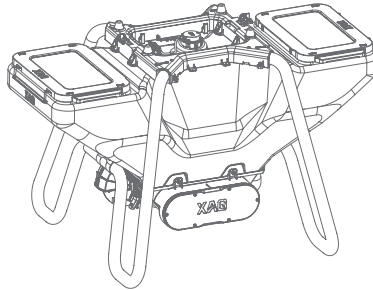

XAG RevoCast P3  
×1

## Main Components

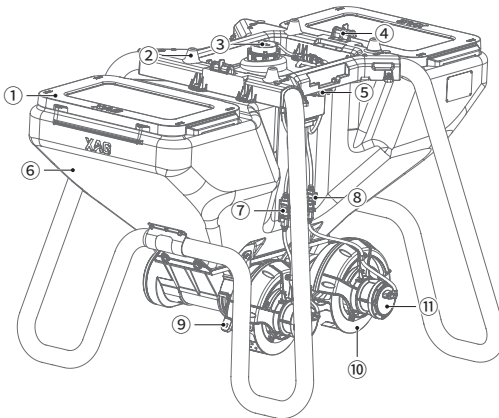

- |                      |                          |                              |
|----------------------|--------------------------|------------------------------|
| ① Cover              | ⑤ Payload System Cable   | ⑨ Hasp of Quick-Release Unit |
| ② Boss               | ⑥ Granule Container      | ⑩ Spreading Disc             |
| ③ Radar Level Sensor | ⑦ Left Disc Motor Cable  | ⑪ Spreading Disc Motor       |
| ④ Hook               | ⑧ Right Disc Motor Cable |                              |

# Installation

As the installation and the use of RevoCast are the same for XAG P100 2023 Agricultural Drone and XAG P100 Pro 2023 Agricultural Drone, the instructions of this user manual are based on the XAG P100 Pro 2023 Agricultural Drone.

## Drain the Liquid

Clean the device before installing the RevoCast as the caustic pesticide could corrode the device, shortening its lifespan. Here are the steps of cleaning.

Detergent: soapy water or laundry powder solution.

### A. Clean the RevoSpray

- ① After adding soapy water or laundry powder solution, start spraying with the "XAG One" App to remove the residual pesticide;
- ② Add clean water and spray again to remove the residual soapy water or laundry powder solution. Drain off any liquid left in the tube to avoid any damage to other things caused by the liquid during the flight.

### B. Clean the aircraft

Use a cloth with soapy water or laundry powder solution to wipe the pesticide stains and mud off the surface of the aircraft.

## Remove RevoSpray

### Remove Spraying Bars

To avoid damage to the spraying bars during spreading, they should be removed before using RevoCast (take the left one for example).

- ① Detach the liquid tube connecting the spraying bar and the arm;

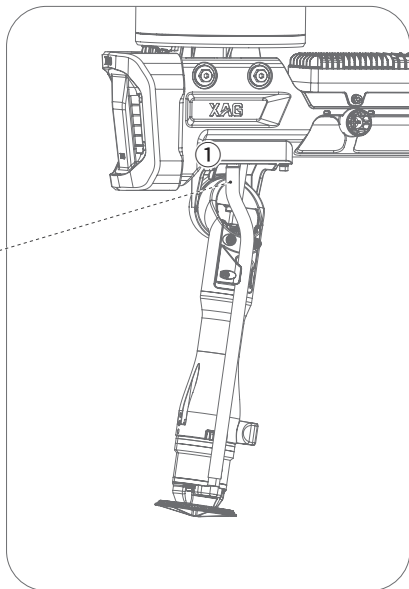
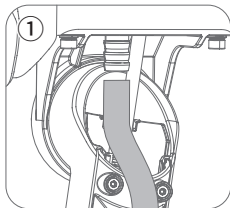

- ② Open the cable cover of the spraying bar by removing the screws, detach the nozzle signal cable and replace the cover;

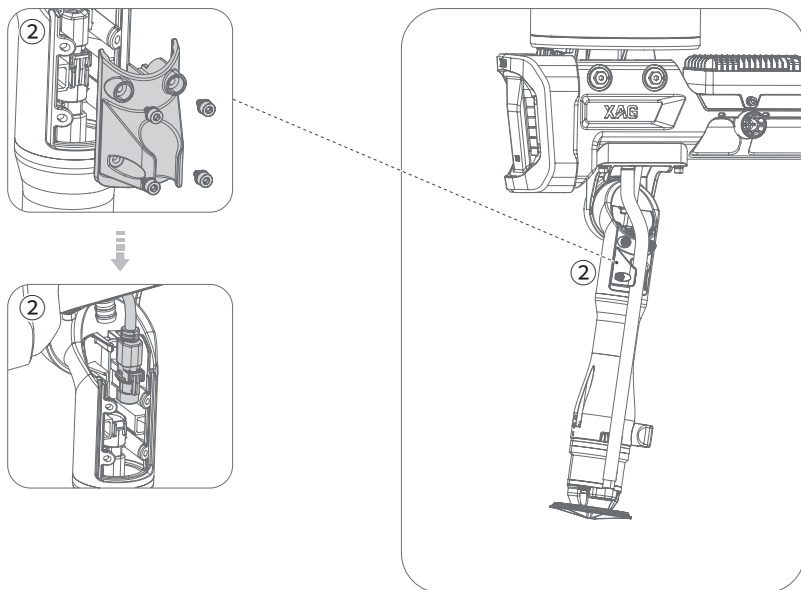

- ③ Fully turn the quick-release knob counterclockwise to remove the bar;  
④ Install the cable organizer, with the connector facing down, to the base of the spraying bar. Tighten the quick-release knob and attach the nozzle signal cable to the organizer.

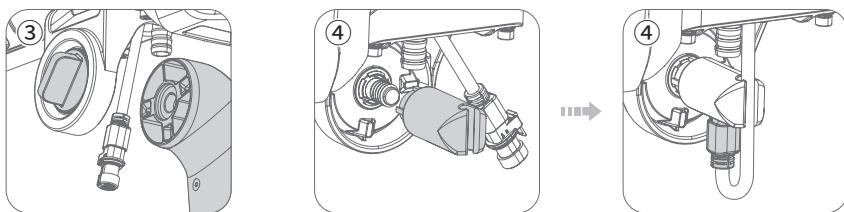

## Remove RevoSpray

- ① Take the payload system cables of the airframe and RevoSpray off the cable holder and detach them;
- ② Remove the two liquid tubes connecting to the pump of RevoSpray;
- ③ Open the left and right hasps (one on each side) and remove RevoSpray.

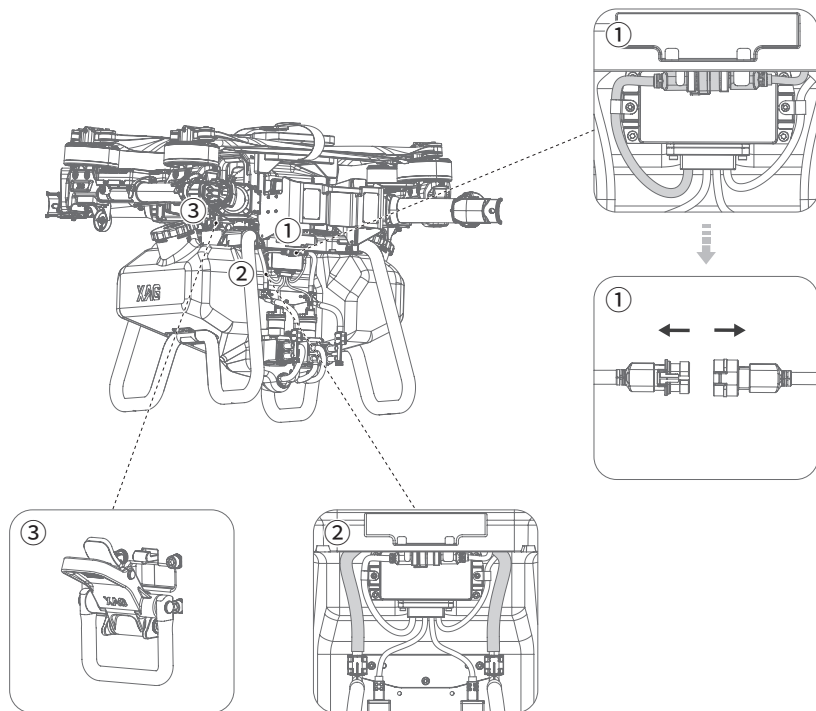

### **Note**

- ⚠ Make sure the liquid tube is free of residual pesticide before installing RevoCast.
- ⚠ Make sure the spraying bars of Arm No.3 and 4 have been removed before using RevoCast. Otherwise, user shall bear the responsibilities for the damage to the components.



## Install RevoCast

- ① Line up the slots on the airframe with the bosses on the RevoCast, and fit the airframe to RevoCast.
- ② Open the two hasps (on the left and right side) on the airframe, and lock them to the hooks of RevoCast.
- ③ Connect the operating system cables of the airframe and RevoCast, and affix them to the cable holder.

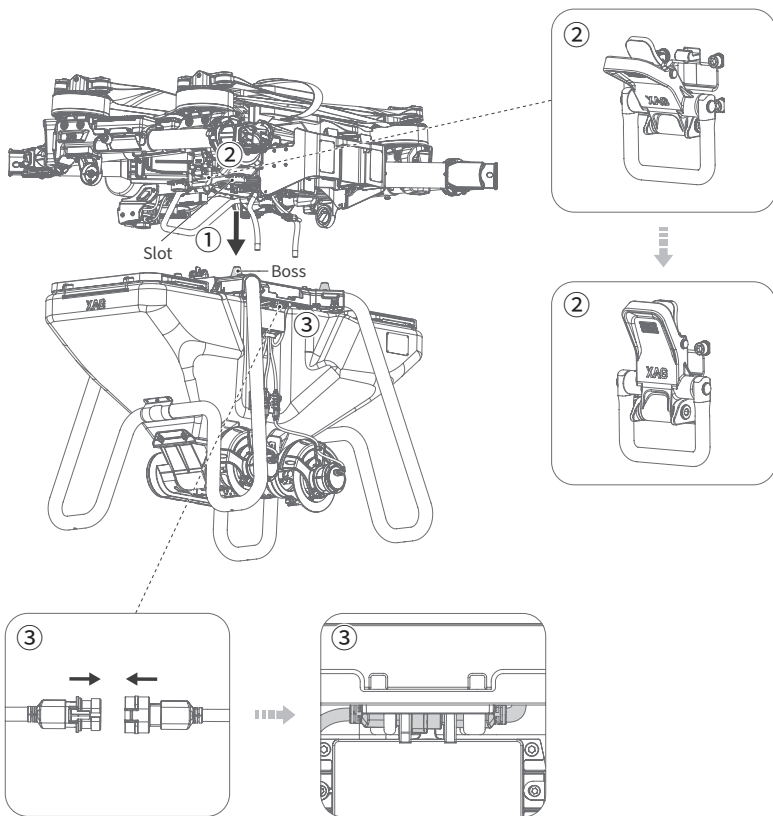

## How to Use

### Firmware Update

Before using the device, if the main page prompts "New firmware available", please update the firmware to the latest version.

1. Open "XAG One" App and tap on "New firmware available" to enter the firmware update page.
2. Tap on "Download and update". After the firmware is updated, tap on "Complete" to go back to the firmware update page, and check if the firmware is updated to the latest version. If not, please update it again until the update is completed.

## Spreading Calibration

Before using RevoCast for the first time or after replacing new granules or screw feeders with different models, spreading calibration is required. Before spreading calibration, you need to remove the spreading disc units on both sides (take the left one as an example).

- ① Disconnect the spreading disc motor cables.
- ② Remove the spreading disc unit by unscrewing its four screws.

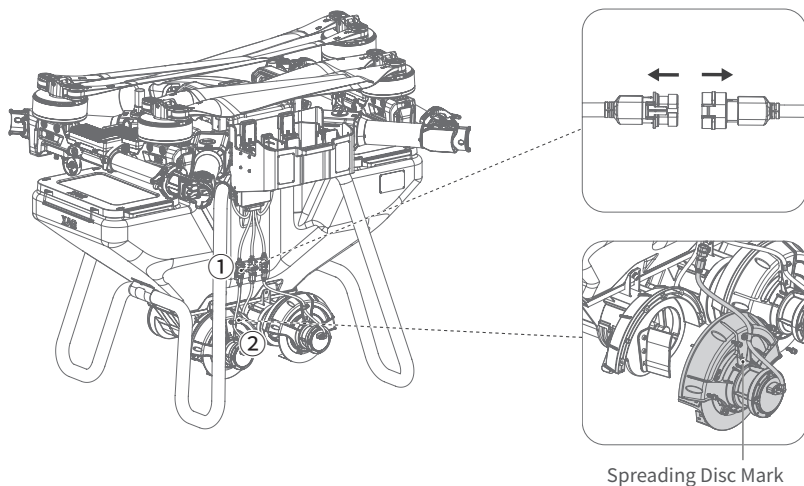

1. Open "XAG One" App and tap on "Me" and then "Device" to select the aircraft and enter Device Details page.
2. Tap on "☼" to enter Spreading System page. Tap on "Granule" and then "⊕" in the upper right corner to create granules. Enter the name of granules to be calibrated, and tap on "OK".
3. Go back to "Spreading System" page after selecting the granule. Tap on "Spreading Calibration", select the screw feeder model and tap on "OK". Add the granules to be calibrated in granule container in excess of 60% volume.
4. Place the aircraft about 50 cm above the ground. Hang the bag/container on the handheld electronic scale, set the scale to zero, and fix the bag/container under both outlets. Check "Empty containers are placed under the outlets" and tap on "Start Calibration".
5. After it stops discharging, use the handheld electronic scale to weigh the bag/container and granules. Fill the actual weight in grams into the App and tap on "Submit" to complete the calibration.
6. After spreading calibration is completed, install the left and right spreading disc units according to the marks ("L" for left and "R" for right) and connect the two spreading disc motor cables.

## Manual Spreading Test

Before spreading, please start "Manual Spreading Test" to make sure the spreading system works well.

1. Open "XAG One" App and tap on "Me" and then "Device" to select the aircraft and enter Device Details page. Tap on "☼" to enter Spreading System page and select "Manual Spreading Test".
2. Tap on "Start" to start manual spreading test.

**Note**

⚠ During manual spreading test, the screw feeders and spreading discs will be rotating rapidly. Please stay away from the aircraft to avoid accidents.

## Spreading Settings

Before spreading, you can set spreading parameters in "Spreading Settings".

1. Open "XAG One" App and tap on "Operation" in the menu bar to enter operation page.
2. Tap on "Select Fields" to select the fields for operation on the map. After that tap on "Spreading Settings".
3. In the spreading settings, you can select "Granule", adjust "Spreading Amount" and set "Change segment for spreading".
4. After the spreading settings and route settings are completed, you can start the aircraft for spreading.

## Maintenance

### Rinse RevoCast

In order to avoid piling up and clogging, rinse RevoCast after daily operation to ensure the spreading efficiency. Rinsing steps are as follows:

- ① Disconnect motor cables of both spreading discs.
- ② Open the hasps of both quick-release units.
- ③ Remove the quick-release units and rinse screw feeders and the cross slots. After rinsing and making sure there is no foreign matters on the quick-release units, air-dry them in a cool place away from direct sunlight.
- ④ Open the granule container covers on both sides, rinse off the residual granules and air-dry in a cool place away from direct sunlight.

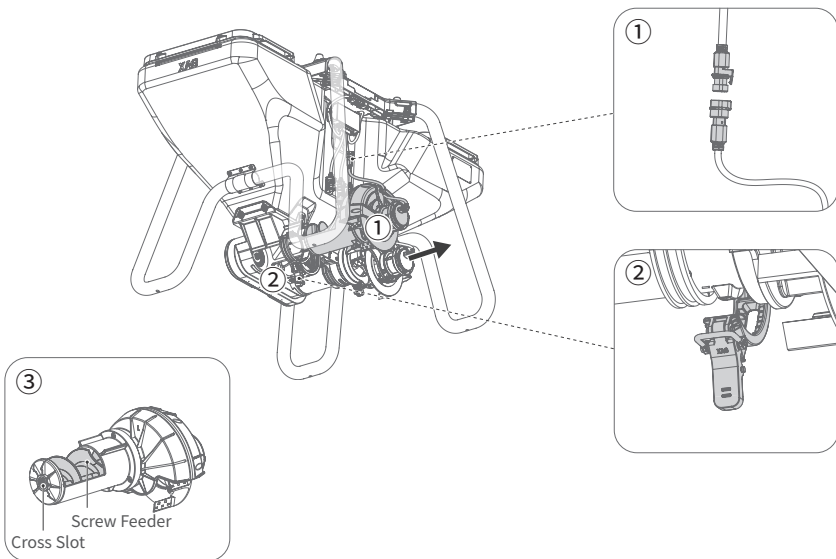

**Note**

- ⚠ If the granules inside are corrosive, please wash RevoCast with soapy water or laundry powder/water mixture first, then rinse it with clean water.
  - ⚠ Residual granules places: 1. In screw feeder speed reduction motor covers. 2. Between the front of spreading disc motors and motor assembling units.
  - ⚠ Speed reducer gears need to be filled with lubricant every 500 hours of operation to ensure that the gears are kept lubricated.
- ⑤ After the quick-release units and containers are air-dried, install the quick-release units and start manual spreading test before the next spreading operation to ensure that RevoCast works well.

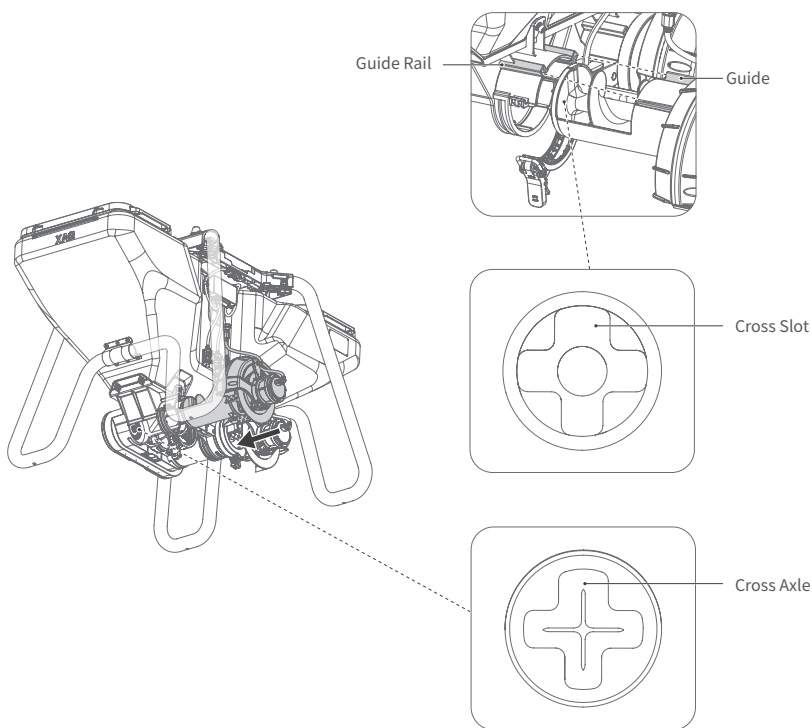

**Note**

- ⚠ Before installing the quick-release units, please follow the "L"/"R" mark to install them in RevoCast to avoid reverse installation.
- ⚠ When installing the quick-release units, align the guides with the guide rails and insert into RevoCast. When inserting, adjust screw feeders to align the cross slots under screw feeders with cross axes of RevoCast. Gently shake and ensure that the quick-release units are installed securely, and then tightly lock the hasps.
- ⚠ If the hasps of quick-release units can't be locked tightly, maybe the quick-release units are not properly installed, please install them again.

## Replace Screw Feeder

If the wear depth on one side exceeds 2 mm (the original diameter is 79 mm), please replace the screw feeders to ensure that RevoCast works well.

- ① Disconnect motor cables of both spreading discs.
- ② Open the hasps of both quick-release units and remove them.
- ③ Unscrew three screws of the screw feeder, replace it with a new one, and restore both quick-release units (refer to page 8).
- ④ After replacing screw feeders, spreading calibration and manual spreading test is necessary to ensure the RevoCast works well before the next spreading.

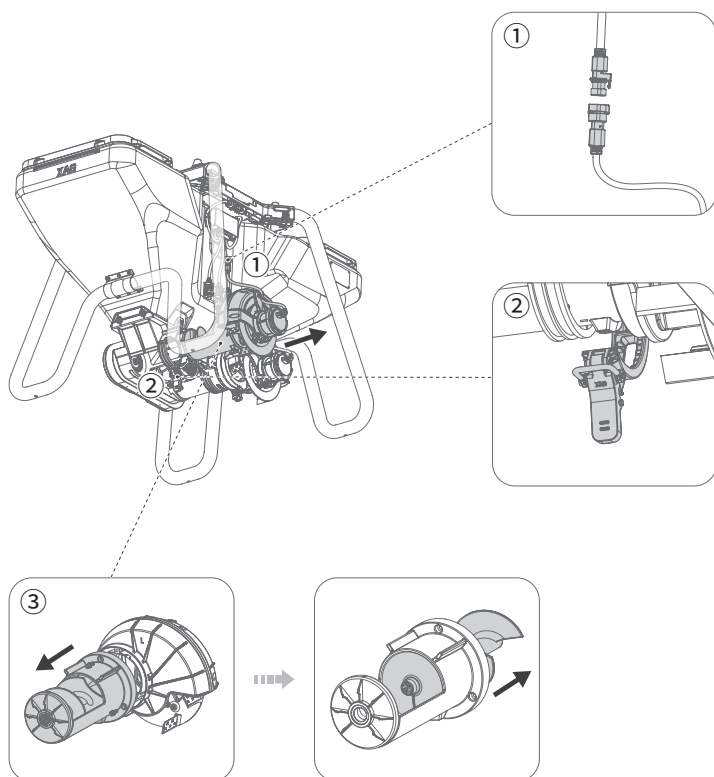

### Note

- ⚠ Please replace with the screw feeders in pairs with the same model. Do NOT use screw feeders different in model and age, otherwise it will lead to a large difference in discharging volume of both screw feeders.
- ⚠ When replacing screw feeders, please correctly install the left/right screw feeders in the corresponding screw feeder units, otherwise it will lead to leakage.

## Granule Examples for Different Sized Screw Feeders

Screw Feeder Size	Granule Example
XL, L	Fertilizer
M	Rice
S	Rapeseed

## Specifications

Model	M4RC-80A-PH
Dimensions	1059 x 728 x 651 mm
Weight	14 kg
Capacity of Granule Container	80 L
Rated Load of Granule Container	XAG P100 2023 Agricultural Drone: 40 kg XAG P100 Pro 2023 Agricultural Drone: 50 kg
Protection Rating	IP65
Ambient Temperature for Operating	0° C to 40° C
Ambient Temperature for Storage	0° C to 40° C
Effective Spread Width	3-7 m (subject to flight height, seed weight, dosage, environment, etc.)
Applicable Granule Size	1-6mm (dry and solid granule)
Spread Amount Accuracy	±10% (subject to granule type and moisture)
Compatible with	XAG P100 2023 Agricultural Drone XAG P100 Pro 2023 Agricultural Drone



Warning: Operation of this equipment in a residential environment could cause radio interference.

“Hereby, [*Guangzhou Xaircraft Technology CO.,LTD.*], declares that this [*XAG RevoCast 3 P100*] is in compliance with the essential requirements and other relevant provisions of *2014/53/EU*.

The full text of the EU declaration of conformity is available at the following internet address: “*www.xa.com/en*”

*Suppliers Name(EU): DRONEUA AGRICULTURE EUROPE Sp. Z O.O.*

*Suppliers Address (EU) : 21-007 Melgiew, Janowice 144 str., Poland.*

*Suppliers phone number and / or internet contact information : (093)4575757*

## KCC Warning Message

이 기기는 업무용 환경에서 사용할 목적으로 적합성 평가를 받은 기기로서 가정용 환경에서 사용하는 경우 전파 간섭의 우려가 있습니다 .

## FCC Supplier's Declaration of Conformity

*Brand name / model number: M4RC-80A-PH*

*This device complies with part 15 of the FCC Rules. Operation is subject to the following two conditions: (1) This device may not cause harmful interference, and (2) this device must accept any interference received, including interference that may cause undesired operation.*

*Suppliers Name(FCC): Pegasus Spray LLC*

*Suppliers Address (FCC): 2235 79th Ave NE, Medina, WA 98039, USA*

*Suppliers phone number and / or internet contact information: +1 (503) 866-1228*

# Disclaimer

1. Please read this User Manual carefully before using this product, as it has much to do with both operational safety and your legitimate rights and interests. You shall be deemed to have read, known, understood, agreed to and accepted all the terms and conditions and information stated herein upon use of the product.
2. Not being a toy and with certain safety risks, this product is not suitable for those who are under 18 years old, those who have no or limited capacity for civil conduct, those with mobility impairments, or those without a UAS operator certificate accredited by XAG or existing laws, regulations and policies. Please keep children away from this product and be particularly cautious with children present.
3. This product is a spreading accessory of XAG P100 2023 Agricultural Drone and P100 Pro 2023 Agricultural Drone solely designed for agricultural use. Be sure to read this User Manual carefully before using this product to understand your legitimate rights and interests, responsibilities as well as safety guidelines. Otherwise, property damage and accidents could be caused; personal safety could be at risk.
4. You pledge to use the product within the bounds of the law for legitimate purposes only and agree to the terms and conditions stated herein as well as potential related policies and norms formulated by XAG. You understand and accept that flight records and data created during use will be automatically uploaded and saved to XAG's server. XAG shall assume no responsibility for the failure to analyze such flight records and data caused by the unsuccessful upload for any reason attributable to the user.
5. To the maximum extent permitted by law, under no circumstances shall XAG offer an implicit or explicit guarantee for this product, including but not limited to implicit guarantees pertaining to vendibility, fitness for a particular use, or non-infringement.
6. Please install, use, transport, and maintain the product under the instructions in this User Manual. Do NOT modify or disassemble this product on your own as any malfunction or damage arising therefrom or resulting from your improper use will not be covered by the warranty, and you shall solely assume the liability arising therefrom, both financially and legally.
7. To the maximum extent permitted by law, XAG shall not be liable for any loss caused by your use of this product outside the instructions in this User Manual. Furthermore, XAG shall not be liable for any indirect, consequential, punitive, accidental, special or exemplary damage, including any loss incurred as a result of your purchase, use, or inability to use the product, even if you have been advised of the possibility of such loss.
8. To the maximum extent permitted by law, under any circumstances, the liability or compensation amount from XAG to you for all damage, losses and litigation arising therefrom will not exceed the amount that you paid to XAG for purchasing the product.
9. You understand that in the use of any products, accidents may occur as a result of single or combined factors, including but not limited to improper operation, surroundings and communication networks. You understand that the aforesaid accidents are reasonable and acceptable in the use of the product, and that XAG shall not be held accountable for such accidents.
10. On any account, purchaser or user shall comply with the laws and regulations of the country and region where the product is used. XAG shall assume no liability arising from the violation of relevant laws and regulations by the purchaser or user.



11. Please note that the services provided by this product and its accessories might involve the collection, storage as well as processing of the geographic information and data of farmland. Before using this product, be sure to comply with local laws and regulations related to the collection, storage and processing of such geographic information and data. Make sure that you use this product in accordance with the law. Any financial and legal liability arising from user's violations of the laws and regulations shall be borne solely by the user.
12. As exclusion clauses may be prohibited by law in some countries, your rights in different countries may vary. However, this does not imply that partial or all terms contained in this Disclaimer are necessarily invalid. For any reason that partial terms stated herein are deemed void, other terms shall remain in effect.
13. To the extent permitted by law, XAG reserves the right for final explanation and revision of the terms and conditions stated hereinabove. XAG also has the right to update, modify or terminate these terms and conditions via its official website, User Manual, online App, etc., without prior notice.

## Warning

Before using a drone and its peripherals, user is required to read through the User Manual and obtain a UAS operator certificate accredited by XAG or the laws, regulations, and policies of the country/region where the product is used. Otherwise, improper operation of the drone and its peripherals may cause serious injury to user or others, or cause damage to the product and property loss. Safety awareness is of great importance during operation. Meanwhile, this product is not suitable for children or those who are under 18 years old, those who have no or limited capacity for civil conduct, or those with mobility impairments as prescribed by law. Please install and use the product by strictly following XAG's instructions in the User Manual. Do NOT use any components that are not provided or suggested by XAG for the repair of the product.



info@xa.com



@XAGofficial



@XAG\_official



**YouTube** @XAG Official